

User Manual

English

2265 Banknote Counter



Print version

[Click here](#) to open a printable version of the manual in the selected language.

Introduction

Thank you for purchasing the Safescan 2265 banknote counter. For proper use and maintenance we advise you to read this user manual carefully.

Please note

Should the equipment be altered in any way or used in a manner for which it was not intended at the time of delivery, the supplier of the equipment accepts no responsibility for injury or damage to personnel or equipment. If the conditions for use of the equipment are changed, the supplier must be contacted or the declaration of conformity will be invalidated.

Safety instructions

- Place the machine on a flat and stable surface.
- Do not place the machine in dusty or dirty environments.
- Use the supplied dust cover when the machine is not in use.
- Do not place the machine in direct sunlight or near heat sources or air conditioners.
- Always disconnect the power cord before performing maintenance on the machine.
- Always connect the machine to an earthed socket outlet.
- Use only the supplied power cord.
- Operation temperature 15-35 °C / 59-95 °F.
- Operation humidity 30-80% R.H.
- Do not use the machine outdoors.
- Do not expose the machine to liquids.
- This machine contains rotating parts. Never touch the moving parts when the machine is switched ON.
- Please ensure that no foreign objects (coins, paper clips, staples) fall into the machine, these may block the mechanical parts and the sensors of the machine and damage or break them and will void your warranty.
- Keep jewellery, long hair, ties and other protruding parts away while operating the machine.
- Never disassemble the machine.
- To prevent shock hazard, do not touch the power cable with wet hands.
- To prevent fire or short circuit, unplug the unit if you want to move it to another position.
- Hold the plug when disconnecting the unit from the power outlet, never pull the cord.

Product overview and box contents

Front

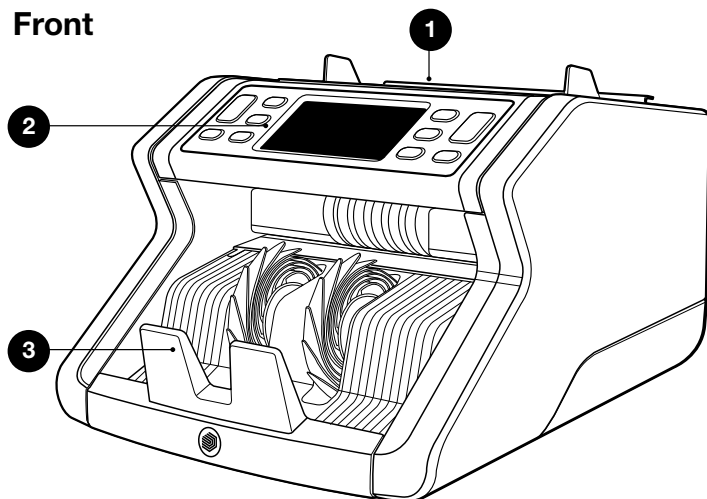

Back

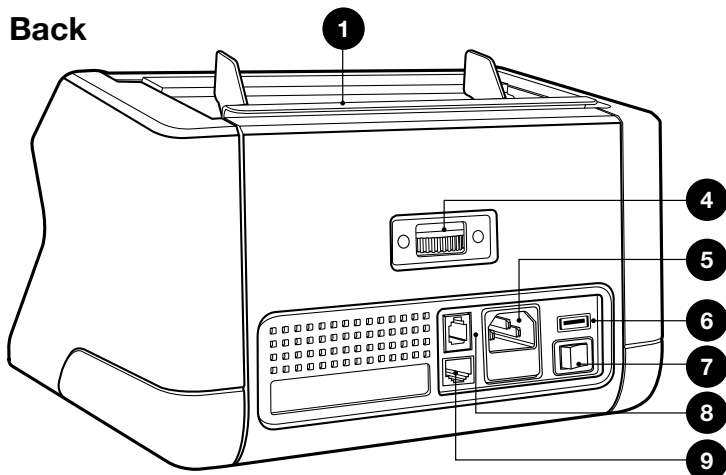

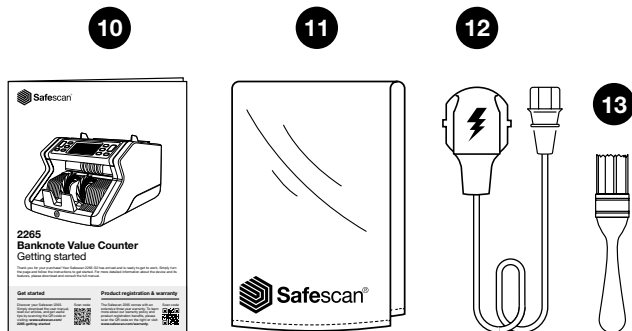

1. Hopper with adjustable guides
2. Display / Buttons
3. Stacker
4. Hopper adjustment wheel
5. Power connector
6. USB port
7. Power On/Off switch
8. RJ10 port for printer and MCS software connection
9. RJ12 port for external display connection
10. Get started folder
11. Dust cover
12. Power cord
13. Cleaning brush

Setting up your machine

1. Remove the protective foil from the LCD screen.
2. Connect the power cable to the machine and the power outlet.
3. Power on the machine with the power switch.
4. The banknote counter will start and perform a self test, during which software version number and product number will be displayed. After a successful self-test, the machine will open the count screen.

Display Overview

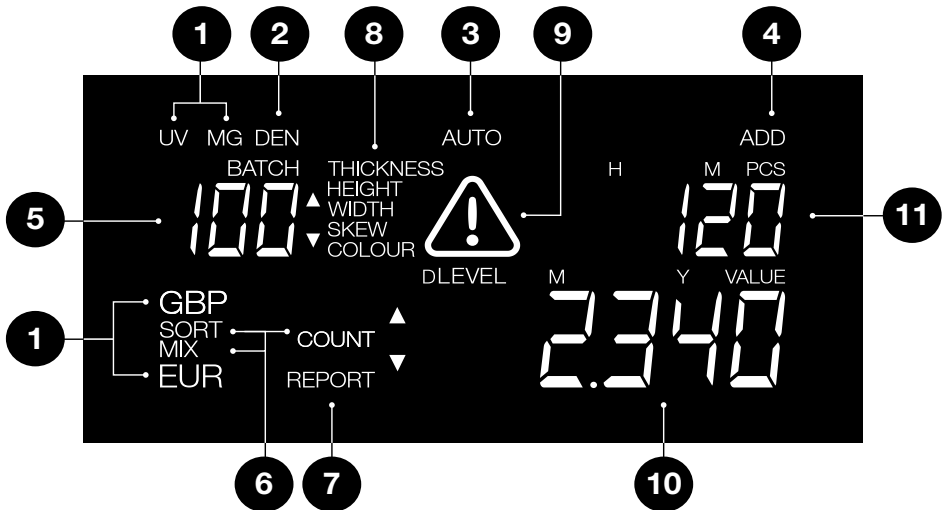









1. Detection type
2. Denomination indicator (visible in Report mode)
3. Automatic count start **ON**
4. Add mode **ON**
5. Batch number
6. Counting mode
7. Report mode **ON**
8. Suspect banknote reason & sensitivity level indicator
9. Error alert
10. Value of counted banknotes (only when **EUR** or **GBP** is selected)
11. Number of counted banknotes

Buttons & display



Buttons

Nr.	Short press	Long press (3 seconds)
1.	 Start counting / Confirm sensitivity level selection / Confirm time and date setting	Select automatic or manual start
2.	 Clear the number of counted banknotes / Go back to count screen	Reset device to default settings
3.	 Add function on/off / Toggle date & time settings	Adjust time and date settings
4.	 Increase Batch number or Sensitivity level by 1 / Start count report loop (low to high denomination, in mix mode only) / Print	

Nr.	Short press	Long press (3 seconds)
5.		Decrease Batch number or Sensitivity level by 1 / Print / Start count report loop (high to low denomination, in mix mode only)
6.		Select counting mode Beep sound on/off
7.		Select currency / detection type Adjust sensitivity settings
8.		Batch function on/off / set batch number

Display

9.	Selected currency and counting mode
10.	Total counted value
11.	Number of counted banknotes

01. Installation

1. Connect the device to an outlet using the supplied power cable.

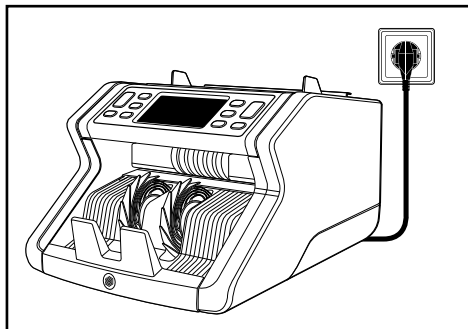

2. Switch on the device via the power button on the back.

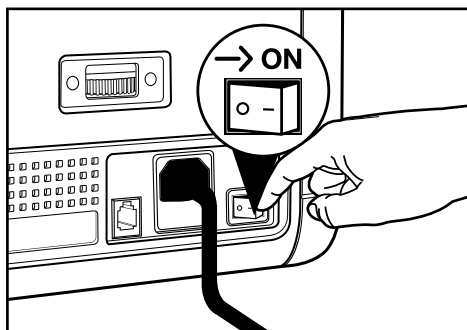

3. Check the currency settings and count your banknotes following the instructions in chapter: **02. Start Counting**

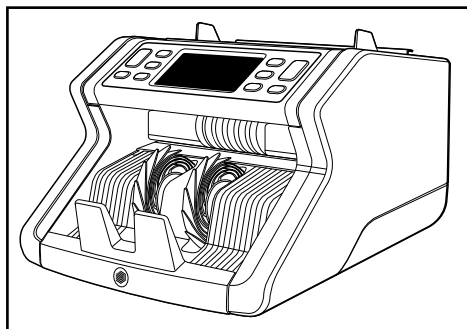

02. First operation

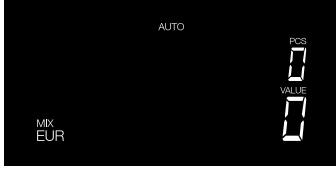

1. The Safescan 2265 starts by default with the following settings:
 - A. Currency: **EUR**
 - B. Counting mode: **MIX**
 - C. Auto start: **ON**

Note: to switch to GBP currency, press [**DETECT**].

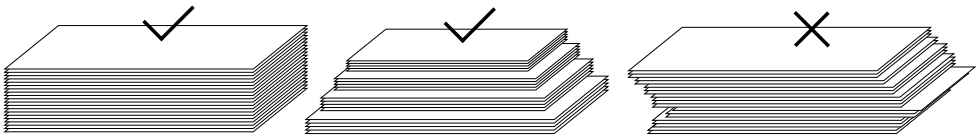

1. Create a neat and compact stack of banknotes and organise them from smallest to largest size.

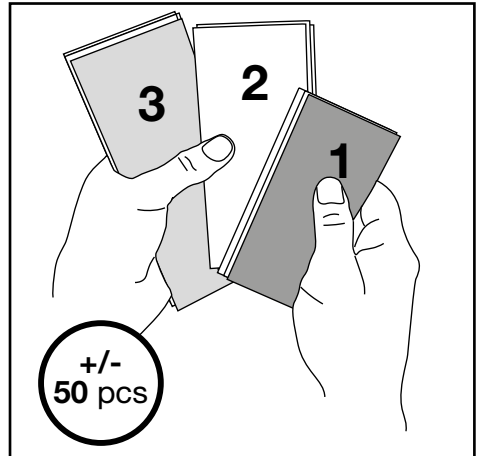

2. Tap the stack on a flat surface and slightly fold the banknotes to align and center them.

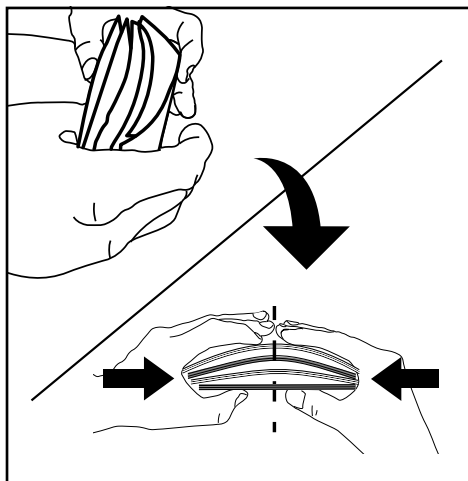

3. Place the stack on the hopper, with the largest banknotes facing up. Then gently push the banknotes back vertically to start counting.

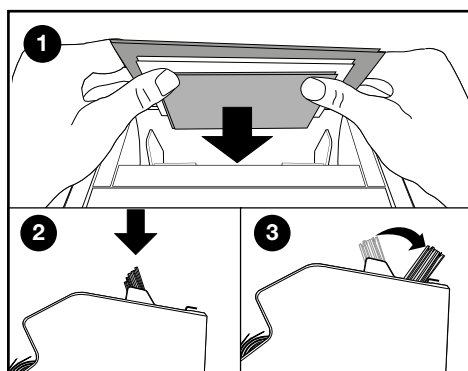

4. Carefully use your hands to guide the banknotes during the count to avoid them slanting or moving.

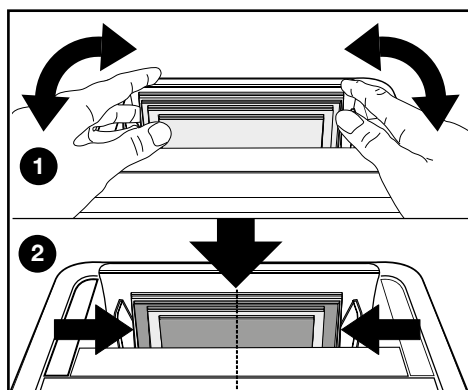

5. When the device detects a suspect banknote during counting, it will stop, sound an alarm and display an error message. The last counted banknote in the stacker is the suspect note. Remove this note and press **[Start/OK]** to continue counting.

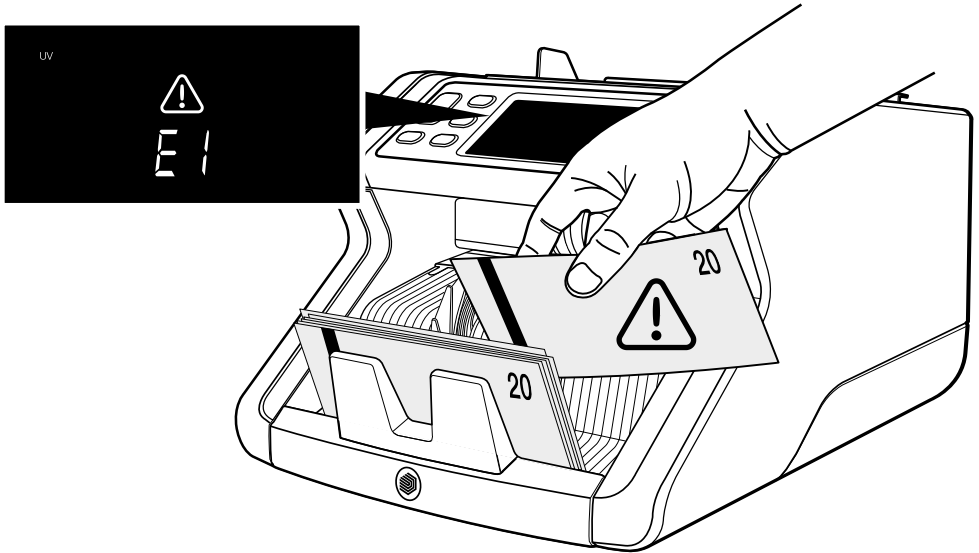

6. After finishing the count, the results are shown on the screen:
- 1: Number of counted notes and total value (for EUR & GBP only).
 - 2: Number of counted notes (for all currencies)

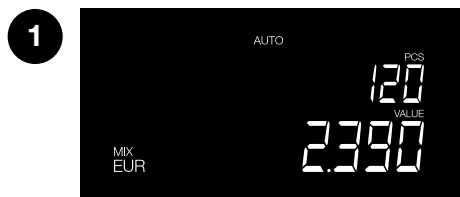

7. When counting **EUR** or **GBP** (in Mix mode only):
press **[arrow up]** or **[arrow down]** repeatedly to view a detailed count report per denomination.



10 pieces of 5 Euro counted



3 pieces of 100 Euro counted

Count modes and detection settings

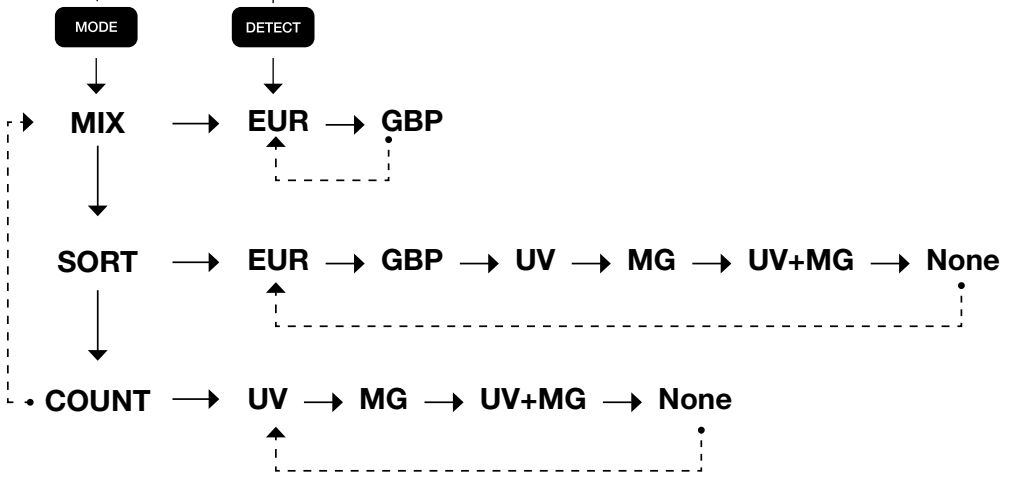
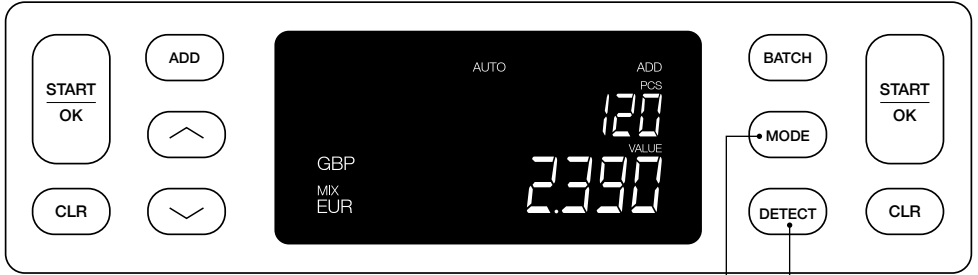

Explanation of the available count modes

Modus	Main feature	Explanation of mode
Mix	Counting the number and value of banknotes.	Counting the number and value of both sorted and unsorted denominations.
Sort	Counting the number and value of banknotes while sorting out different sized banknotes.	Counting the number and value of banknotes sorted per denomination. Denominations that have a different height or width than the first counted banknote are rejected.
Count	Counting the number of banknotes or sheets.	Counting the number of banknotes or sheets without checking on size.

Batch counting

The Batch function is used to create stacks of an equal number of banknotes. The counter will stop when the set batch number has been reached.

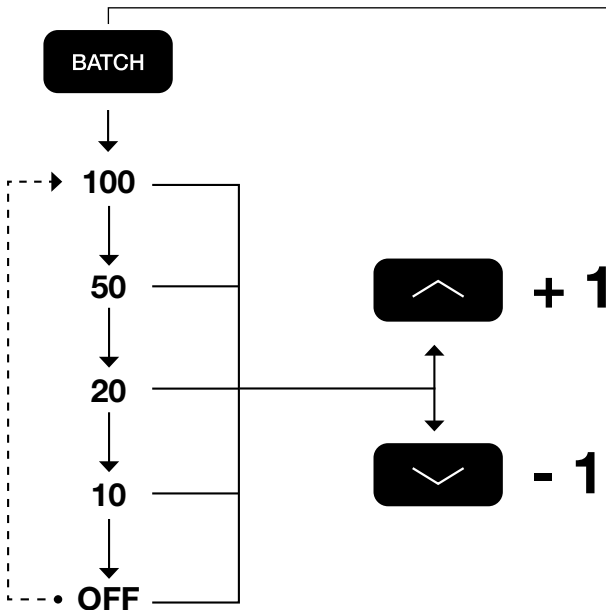
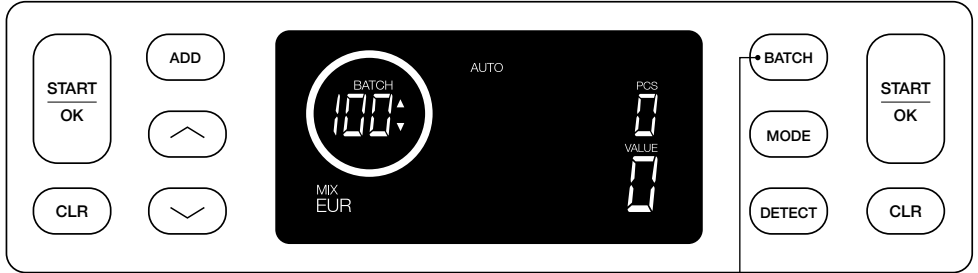

Add function

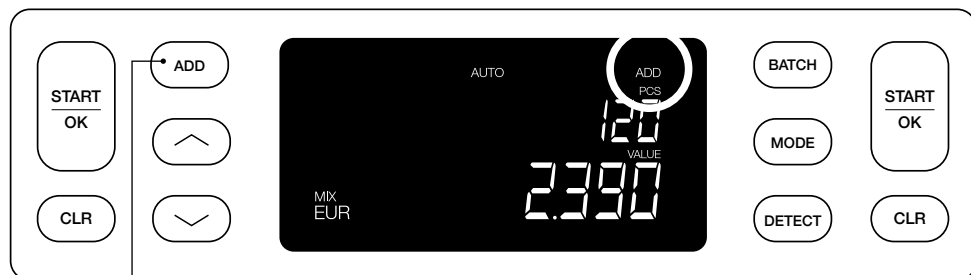

ADD

ON

Count results are added to the previous result.

OFF

Previous count result is cleared when a new count is started.

Count report & Print count results (for EUR & GBP, in Mix mode only)

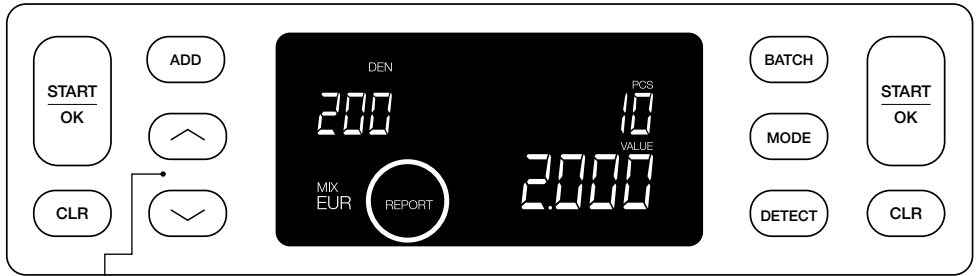

↓
→ **Lowest denomination** → Number and value are shown.

↓
Highest denomination → Number and value are shown.

↓
Print

↓
→ **Return to count screen** → Press **[Start/OK]** to print count results on the optional Safescan TP-230 printer.







Adjusting counterfeit detection settings

Your banknote counter has already been pre-configured with the optimal detection settings for this type of banknote counter. On rare occasions it could be required to manually adjust the sensitivity of one or more counterfeit detection settings.

Note: Only adjust these settings when being advised to do so by a Safescan technical expert.

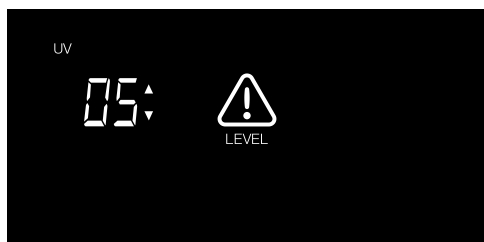

To change the detection settings:

1. Press the **DETECT** button for 3 seconds to open the Detection Settings mode. The first available setting (UV) starts blinking. On the display the current level setting is shown.
2. To move to another detection type, press  or  until the desired detection type has been reached.
3. Press **START/OK** to change the level. 2 arrow indicators next to the current level setting will start blinking.
4. Press the  or  buttons to set a new detection level.
5. Press **START/OK** to confirm the detection level and return to the count screen.



Note: Press **[CLR]** to cancel and return to count screen at any time during this process.

Set time and date



1. Press **ADD** button for 3 seconds to set time and date. The currently set time is shown. The item that can be changed is blinking, starting with Hours (H).
2. Press **ADD** to toggle to the next item. The sequence is Hours (H) > Minutes (M) > Day (D) > Month (M) > Year (Y).
3. Press  or  to change the setting of the selected item up or down by 1.
4. When done, press **START/OK** to save the settings and go back to the count screen



Note: Press **[CLR]** to cancel and return to count screen at any time during this process.

Button & alarm sound on / off

By default the alarm sound is switched **ON**. This sound can be switched off.

1. Press **MODE** for 3 seconds to enter Sound Settings. The current setting will blink.
2. Press  or  to toggle between “**ON**” and “**OFF**”.
3. Press **START/OK** to save the settings and go back to the count screen.



Maintenance

To ensure that operation and reliability of your device remain at an optimal level, follow the below cleaning instructions on a regular basis (recommended: every 1 or 2 weeks). Counting banknotes generates dust which can end up on the sensors. This will influence the functioning of the device.

Cleaning the device

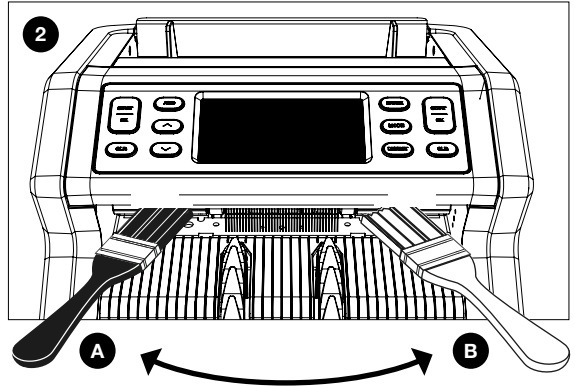
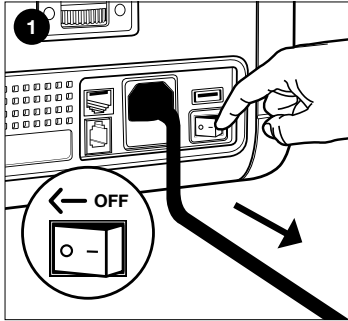

1. Switch off the device and remove the power cord.
2. Place the brush in the gap between the top and bottom part. Move the brush from side to side, make sure the brush touches the top as well as the bottom.
3. Follow this procedure for both left **(A)** and right hand side **(B)**.

RECOMMENDATION:

- Clean the device every 1 or 2 weeks.
- Additionally, for optimal maintenance the use of an air duster to remove dust is highly recommended.

Cleaning cards (option)

You can also use the Safescan banknote counter cleaning cards (article no. 152-0663) to clean the roller wheels and magnetic sensors. For more information see www.safescan.com.

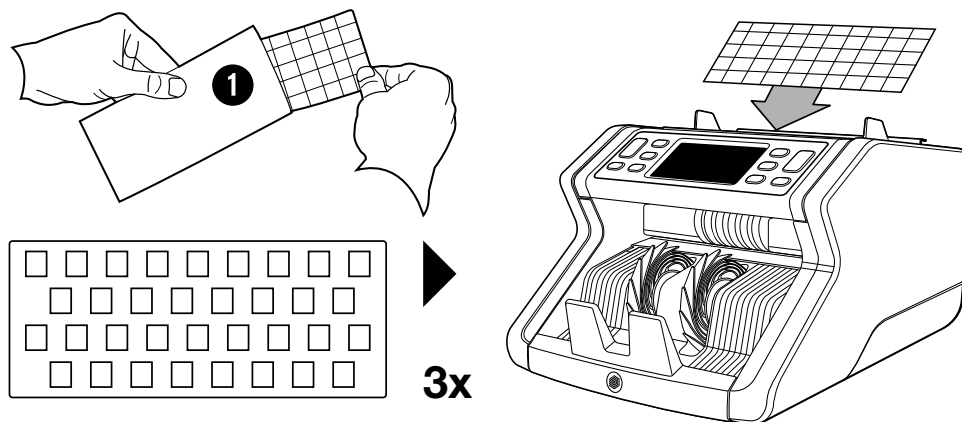

Adjusting the feeding gap

When thickness or skewed note counting errors occur frequently, or when banknotes are not being fed smoothly through the machine, it may be necessary to adjust the hopper adjustment wheel. This wheel controls the thickness distance of the banknotes. The position of the hopper wheel has already been set in optimal position in the factory. However, due to the nature of some banknotes an adjustment may be required to ensure optimal feeding.

- When the banknotes are not being counted smoothly: increase the note thickness distance by turning the adjustment wheel clockwise (-).
- When counting errors like “thickness” (double notes) or “skewed notes” occur, decrease the note thickness distance by turning the sensitivity wheel anti-clockwise (+).

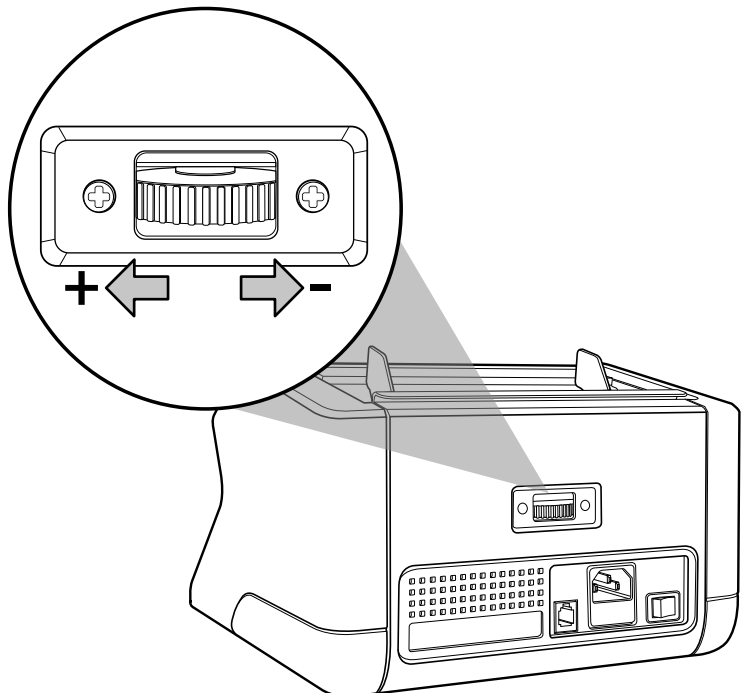

Troubleshooting: Error message overview

Once the machine can not properly verify the security features or detects a problem with a banknote, it will stop counting and show a clear message including the type of issue. The error concerns the last counted banknote in the stacker. The following messages are possible:

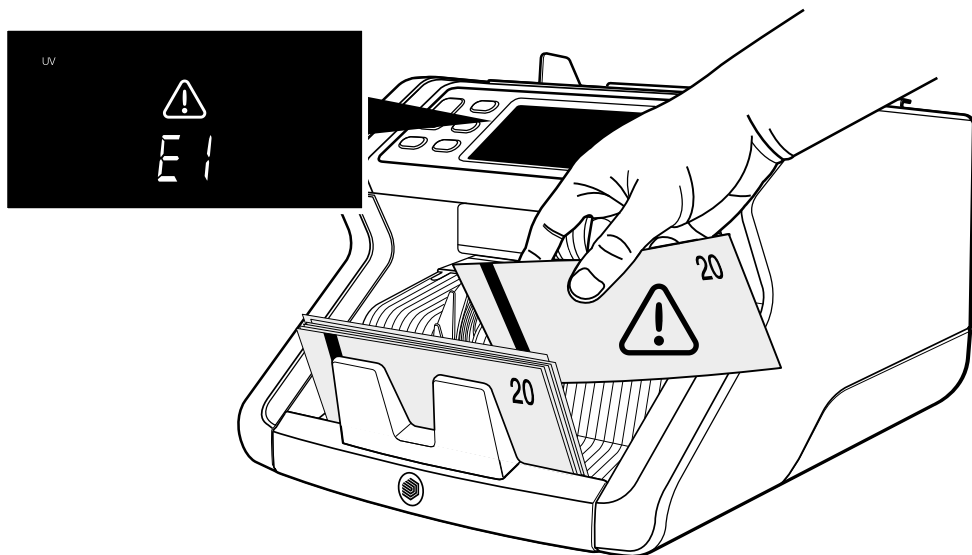

Error message	Cause	Solution(s)
E1 (UV)	<ul style="list-style-type: none">- Banknote is a suspected counterfeit.- The integrated UV features of banknotes may become weaker when a banknote is old / heavily used or when it has accidentally been washed with the laundry.	<ul style="list-style-type: none">- Count the banknote again to double check if the problem persists.- Make sure that the device is not under direct strong light source since this may disrupt the UV sensors.- Clean the sensors and remove any dust that may have accidentally blocked the sensors.- If the banknote is in fact genuine, lower the UV sensitivity level and count the banknote again.

Error message	Cause	Solution(s)
E2 (MG)	<ul style="list-style-type: none">- Banknote is a suspected counterfeit.- Some currencies are known to have very weak MG features in certain banknote denominations, which are almost impossible to detect.- Some currencies may not have MG features integrated at all.	<ul style="list-style-type: none">- Count the banknote again to double check if the problem persists.- Clean the magnetic sensors with a banknote cleaning card.- If the banknote is in fact genuine, lower the MG sensitivity level and count the banknote again.
E3 (thickness)	<ul style="list-style-type: none">- The measured thickness is not in line with what is expected from a banknote.- Banknote is a suspected counterfeit.- 2 banknotes may be stuck together.	<ul style="list-style-type: none">- Double check the rejected banknote on paper quality.- Separate the banknotes if they are stuck together.

Error message	Cause	Solution(s)
E4 (height)	<ul style="list-style-type: none">- Height is different than the first counted banknote (sort mode only).- Height does not match with the denomination (EUR and GBP currency setting only).- Banknote may be torn, folded or damaged.	<ul style="list-style-type: none">- Sort the banknotes per denomination if you are counting in 'sort' mode.- Always feed the notes in the middle of the hopper, use the hopper guides to center the notes.- When counting polymer notes, due to the window in the note it may be seen as 'incomplete' note if it passes the height measuring sensors. Re-count the banknote to see if the problem persists.

Error message	Cause	Solution(s)
E5 (width)	<ul style="list-style-type: none">- Width does not match with the denomination (EUR and GBP currency setting only).- Banknote may be torn, folded or damaged.	<ul style="list-style-type: none">- Always feed the notes in the middle of the hopper, use the hopper guides to center the notes.- When counting polymer notes, due to the window in the note it may be seen as 'incomplete' note if it passes the width measuring sensors. Re-count the banknote to see if the problem persists.
E6 (skew)	<ul style="list-style-type: none">- The banknotes are not being fed straight through the machine.	<ul style="list-style-type: none">- Ensure the banknotes are placed neatly. Use the hopper guides to center the banknotes. When counting a large stack of banknotes, guide the notes also with your hands during counting.

Error message	Cause	Solution(s)
E7 (colour) (EUR, GBP only)	<ul style="list-style-type: none">- The detected color does not match with the denomination.	<ul style="list-style-type: none">- Count the banknote again to see if the problem persists. When yes, the note may be a suspected counterfeit.- Ensure that the correct currency has been selected.
Size detection does not work	<ul style="list-style-type: none">- All banknotes within the counted currency are of the same height (for example USD, CHF, CAD, AUD, HUF)- The difference in height between the various denominations may be too little to detect (minimum 5 mm)	
EA0 ~ EA5 errors on startup	Ensure that there are no banknotes present in the stacker (EA2 error) and/or that no banknotes or other objects are blocking any internal parts of the machine. When the error message remains, contact Safescan technical support for assistance.	

Error message	Cause	Solution(s)
----------------------	--------------	--------------------

When a problem / error message persists after multiple attempts to count the banknote and you have ensured that the machine settings are correct and the banknote quality is acceptable, the banknote may be a suspected counterfeit. Present the note to your bank to have the banknote officially assessed.

Technical Specifications

Supported currencies:	EUR, GBP, all currencies
Counting modes:	Mix (EUR, GBP) Sort (EUR, GBP, all currencies) Count (all currencies)
Counting speed:	1200 banknotes/minute
Banknote feature detection:	UV features, MG features, Color, Size (height, width), Thickness
Banknote size range:	50 x 110 mm ~ 90 x 180 mm
Hopper capacity:	150 banknotes
Stacker capacity:	220 banknotes
Power:	AC 220-240V / 50-60Hz.
Power consumption:	max. 60W
Dimensions:	29.5 x 25 x 18.4 cm / 11.6 x 9.8 x 7.2 inch
Weight:	5.8 kg / 12.8 lbs
Operating Temperature:	0 ~ 40°C

Technical Support

Please visit our online support center first - go to **support.safescan.com** and select 'Banknote Counters'.

If you need any further assistance: our support team is available by phone during office hours (GMT +1 timezone) or by e-mail to answer any question you may have regarding the usage of your Safescan device. Visit www.safescan.com for details.

When calling or e-mailing our support center, always make sure you have the following information at hand: model number, serial number (see product sticker at the bottom of the device), software version number (shown at startup of the device) and date of purchase.

Serial number



Software version number

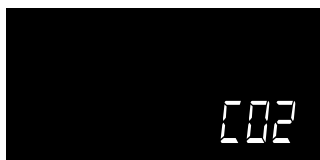

Warranty

Warranty procedure: contact Safescan for assistance: **www.safescan.com/warranty**

CE This product is in compliance with the essential requirements and other relevant provisions of the applicable European directives. The Declaration of Conformity (DoC) is available at **www.safescan.com**



Take the device to a recycling centre if you want to dispose of it. Never dispose of any electronic devices with household waste.

Safescan®

Safescan B.V.

PO Box 7067, 2701AB Zoetermeer, NL
Designed in Europe - Made in China
www.safescan.com

© 2023 Safescan. All rights reserved
SAFESCAN® is a registered trademark

www.safescan.com

20231